

Feature

- High density, more than 1 resistors in one small case
- The Concave design in terminal enlarge the Soldering plate area
- The Concave design to reduce the terminal breaking risk
- Improvement of placement efficiency
- Application: RAM, CD & DVD Rom, Hard Disk, Master board

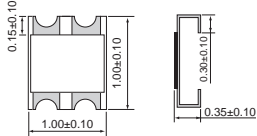
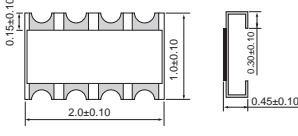
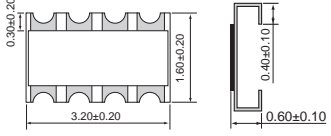
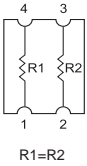
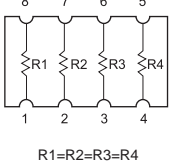
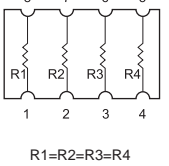

	2C02	4C02	4C03
Dimension (mm)			
Equivalent Circuit Diagram	 <p>R1=R2</p>	 <p>R1=R2=R3=R4</p>	 <p>R1=R2=R3=R4</p>

	2C02	4C02	4C03
Type	2C02	4C02	4C03
Rated power at 70°C	1/16W	1/16W	1/16W
Max. Working Voltage	25V	25V	50V
Max. Overload Voltage	50V	50V	100V
Dielectric withstanding Voltage	100V	100V	300V
Resistance Range	5% (E-24): 10Ω~1MΩ 1% (E-96): 10Ω~1MΩ	5% (E-24): 10Ω~1MΩ 1% (E-96): 10Ω~1MΩ	5%, 1%: 1Ω~1M
Temperature coefficient	±200PPM/°C	±200PPM/°C	≥ 10Ω: ±200PPM/°C < 10Ω: ±400PPM/°C
Operating Temperature	-55°C~+155 °C	-55°C~+155 °C	-55°C~+155 °C
Resistance Value of Jumper	<50mΩ	<50mΩ	<50mΩ
Rated Current of Jumper	1A	1A	1A

Performance Specification

Short-time overload	±(2.0% ±0.1Ω) Max.
Insulation resistance	≥ 1,000 Mega Ohm.
Dielectric withstanding voltage	No evidence of falshover, mechanical damage, arcing or insulation breakdown
Terminal bending	±(1.0% ±0.05Ω) Max.
Soldering heat	ΔR/R ≤ ±(1.0% ±0.05Ω)
Solderability	Min.95% coverage
Temperature cycling	ΔR/R ≤ ±(1.0% ±0.05Ω)
Load life in humidity	±(3.0% ±0.1Ω) Max.
Load life	±(3.0% ±0.1Ω) Max.

• Please refer to page 4 for the information of Ordering Procedure (Part No.)